

(19)



Europäisches Patentamt

European Patent Office

Office européen des brevets



(11)

EP 1 045 578 A2

(12)

EUROPEAN PATENT APPLICATION

(43) Date of publication: 18.10.2000 Bulletin 2000/42

(51) Int. Cl.7: H04N 5/217

(21) Application number: 00302082.3

(22) Date of filing: 15.03.2000

(84) Designated Contracting States: AT BE CH CY DE DK ES FI FR GB GR IE IT LI LU MC NL PT SE Designated Extension States: AL LT LV MK RO SI

(72) Inventors: • Chen, Zhiliang Jullan, Plano, Texas 75093, (US) • Dierschke, Eugene G., Dallas, Texas 75248, (US) • Clynes, Steven Derek, Allen, Texas 75002 (US) • Liu, Anli, Plano, Texas 75024, (US)

(30) Priority: 15.03.1999 US 124408 P 30.12.1999 US 475652 15.03.1999 US 124538 P

(74) Representative: Legg, Cyrus James Grahame et al ABEL & IMRAY, 20 Red Lion Street London WC1R 4PQ (GB)

(71) Applicant: Texas Instruments Incorporated Dallas, Texas 75251 (US)

(54) Filtering of defective picture elements in digital imagers

(57) Defective pixels in a CMOS array give rise to spot noise that diminishes the integrity of the resulting image. Because CMOS arrays and digital logic can be fabricated on the same integrated circuit using the same processing technology and relatively inexpensive and fast circuit can be employed to digitally filter the pixel data stream and to identify pixels having values that do not fall in the range defined by the immediately neighboring pixels and the deviate from the neighboring pixels

els by more than a threshold amount. Such conditions would indicate that the deviation is caused by a defective pixel rather than by desired image data. The threshold amount can be preprogrammed or can be provided by a user or can be dynamically set using feedback indicating image quality. The filter would also provide a solution for other sensors such as CCD.

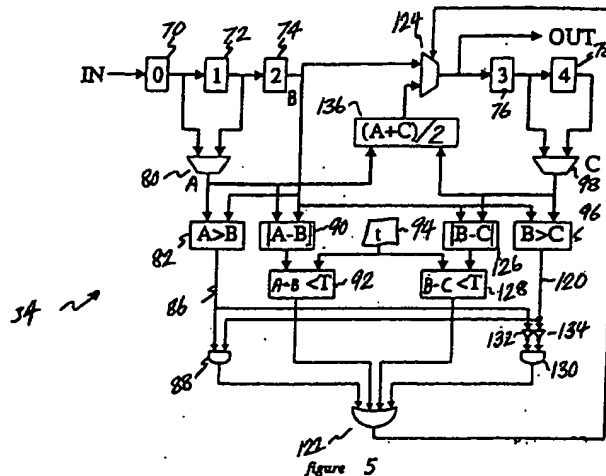

EP 1 045 578 A2

Description

[0001] This application claims benefit of U.S. Patent Applications Nos. 60/124408 and 60/124538 filed on 15 March 1999 and 09/475652 filed on 30 December 1999 which applications are incorporated herein by reference. Copies of US 60/124408 and US 60/124538 are available for inspection in the file of this application.

[0002] This application is related to and accompanied by a copy of a commonly assigned, co-pending European patent application entitled "Digital imaging control with selective intensity resolution enhancement" (Applicant Docket No. TI-29033) filed concurrently herewith and incorporated herein by reference. A copy of the co-pending European patent application entitled "Digital imaging control with selective intensity enhancement" is available for inspection in the file of this application.

[0003] This invention relates generally to digital imaging devices and specifically to techniques and circuits for the filtering of defective picture elements. The term pixels is used below to mean picture elements.

[0004] Digital imaging devices are becoming increasingly popular in a variety of applications, including digital cameras, fingerprint recognition, digital scanners and copiers, and the like. Typical prior art digital imaging devices are based on charge coupled device (CCD) technology. CCD devices have an array of CCD cells, each cell comprising a pixel. Each CCD pixel outputs a voltage signal in proportion to the intensity of light impinging upon the cell. This analog voltage signal can be converted to a digital signal for further processing, digital filtering, storage and the like. As is well known in the art, a two dimensional digital image can be constructed from the voltage signals output from a two-dimensional array of CCD cells, commonly referred to as a sensor array.

[0005] CCD arrays have a shortcoming in that CCD fabrication requires a special process that is not compatible with standard CMOS processes. Thus, the CCD array cannot be easily integrated with other logic circuits, such as CCD control logic, analog to digital converters and the like. Additionally, in operation, a CCD array requires multiple high voltage supplies from 5V to 12V and CCD arrays tend to consume a large amount of power in use.

[0006] An alternative to CCD arrays is using an array formed of CMOS cells. A CMOS sensor array can be fabricated using standard CMOS processing and thus can be integrated onto a single chip with other circuits, such as array control logic, analog to digital converters (A/D's), digital signal processing (DSP) cores and the like. CMOS arrays provide the additional advantage of operating with a single low supply voltage such as 3.3V or 5V, and consuming less power than a comparable CCD array. Finally, a CMOS array can be fabricated at a lower cost than a similar CCD array.

[0007] One common problem with both CCD and with CMOS imaging devices is that of point defects

which cause "spot noise" on the image, such as white spots on a dark portion of the image or a dark spot on a white portion of the image. In CMOS imaging devices, white spots are due to pixels (i.e. CMOS cells) with excessive leakage current. Dark spots are due to either particles covering the pixel or a defect in the pixel electronics causing the pixel not to turn on. Spot noise seriously limits the yield of CMOS imaging devices, resulting in increased costs.

[0008] One method to remove spot noise electronically has been proposed by Younse et al. in U.S. Patent 4,805,023. The Younse et al. implementation requires expensive EPROM memory and involves a complicated hardware system, further increasing the cost of the imaging device. Furthermore, the solution proposed by Younse et al. cannot remove temperature dependent spot noise, such as white spots appearing only at high temperatures.

[0009] Therefore, a need exists for a relatively inexpensive filter that can quickly and reliably filter out the effects of defective pixels, including spot noise, from an image signal.

[0010] The invention provides a filter for filtering an image which includes a plurality of picture elements each represented by a luminance or a chrominance value, including:

means for selecting a picture element and its two adjacent picture elements,

means for determining whether the selected picture element lies between the two adjacent picture elements in value,

means for determining whether the selected picture element differs in value from both of the two adjacent picture elements by more than a set amount and

means for replacing the selected picture element, in value, by a value dependent on the two adjacent picture elements, when, in value, the selected picture element does not lie between the two adjacent picture elements and differs from both of the two adjacent picture elements by more than the set amount and

means for repeating the procedure for further picture elements serving as the selected picture element.

[0011] One embodiment of the invention is a digital imaging device comprising a substrate, a sensor array formed on the substrate, the array generating an electrical signal corresponding to the amount of light impinging upon the array, and imaging logic formed on the substrate, coupled to the sensor array and receiving the electrical signal. The imaging logic includes an analog to digital converter receiving the electrical signal and outputting digital pixel values and a defective pixel filter receiving the digital pixel values and detecting defective pixels on the basis of variations between a selected

pixel value and its neighboring pixel values.

[0012] Another embodiment of the invention is a digital imager comprising a lens mechanism, a sensor array positioned within a focal plane of said lens mechanism, and an analog buffer and amplifier coupled to an output of said sensor array, and imaging logic coupled to said amplifier. The imaging logic includes a defective pixel filter comprising means for detecting whether a first pixel is outside an acceptable range defined by luminance values of first and second neighboring pixels, means for determining whether said first pixel deviates from said first neighboring pixel by greater than a threshold value and means for determining whether said first pixel deviates from said second neighboring pixel by greater than a threshold value, means for calculating a corrected pixel value, and means for substituting said corrected pixel value for said first pixel if said first pixel is outside said acceptable range and said first pixel deviates from said first neighboring pixel by greater than a threshold value and said first pixel deviates from said second neighboring pixel by greater than a threshold value.

[0013] The invention also provides a method of filtering an image including a plurality of picture elements each represented by a luminance or a chrominance value, including the steps of:

selecting a picture element and its two adjacent picture elements,
 determining whether the selected picture element lies, in value, between the two adjacent picture elements,
 determining whether the selected picture element differs, in value, from both of the two adjacent picture elements by more than a set amount and when the selected picture element does not lie, in value, between the two adjacent picture elements and differs from both of the two adjacent picture elements by more than the set amount,
 replacing the selected picture element, in value, by a value dependent on the two adjacent picture elements,
 the procedure being repeated for further picture elements serving as the selected picture element.

[0014] A method is provided for detecting a defective pixel based upon the luminance values generated by the pixel and its two nearest neighbors. The method includes determining a first difference value between the luminance value of the pixel and the luminance value of a first neighboring pixel and comparing the first difference value to a pre-determined threshold value. The method also includes determining a second difference value between the luminance of the pixel and the luminance value of a second neighboring pixel and comparing the second difference value to the pre-determined threshold value. Finally, the method includes detecting whether the luminance value for the pixel falls

within an acceptable range defined by the luminance value for the first neighboring pixel and the luminance value for the second neighboring pixel and identifying the pixel as defective if the luminance value for the pixel does not fall within the acceptable range and neither the first difference value nor the second difference value is less than or equal to the threshold value.

[0015] The above features of the present invention will be more clearly understood from consideration of the following descriptions in connection with accompanying drawings in which:

Figure 1 illustrates a digital imaging device in which preferred embodiments of the invention may be employed;

Figure 2 is a block diagram of a preferred embodiment single chip CMOS imaging device;

Figures 3a through 3j illustrate various acceptable and unacceptable variations between neighboring pixels and

Figures 4a through 4c illustrate the preferred embodiment filter of defective pixels operating as a moving window of analysis;

Figure 5 schematically illustrates a first preferred embodiment circuit for filtering out defective pixels and

Figure 6 illustrates a portion of a color sensor array.

[0016] The making and use of the various embodiments are discussed below in detail. However, it should be appreciated that the present invention provides many applicable inventive concepts which can be embodied in a wide variety of specific contexts. The specific embodiments discussed are merely illustrative of specific ways to make and use the invention, and do not limit the scope of the invention.

[0017] Figure 1 illustrates a digital imaging device 2 utilizing preferred embodiments of the present invention. Digital imaging device 2 includes a lens mechanism 4 which receives light emanating or reflected from an object to be imaged and focuses the incoming light upon an array sensor 6. The array sensor 6 is preferably a CMOS sensor array of the type fully described in co-pending patent application 09/223,166, entitled Fast Frame Readout Architecture for Array Sensors with Integrated Correlated Double Sampling System, which application is incorporated herein by reference. As will be known to one skilled in the art, the sensor array 6 is comprised of a two dimensional array of CMOS sensors, each sensor corresponding to a pixel of the resulting image. Each sensor outputs an analog voltage signal, which signal is in proportion to the intensity of light impinging upon the particular sensor. The voltage signal from each sensor can be scanned in a raster format as is well known in the art to generate an analog image signal. This analog image signal is fed to imaging logic 8 where the analog signal is buffered and amplified before being converted to a digital signal. The digital

signal can be filtered or further processed before being passed to an input / output (I/O) port 10 in the form of pixel intensity data. Alternatively, with additional signal processing, the digital signal can be output in the form of a bitmap or other well known digital picture format.

[0018] Alternatively, the digital signal can be passed to a memory 12 for storage. The memory 12 is preferably a dynamic random access memory or a static random access memory. Alternatively, the memory 12 could be a magnetic or optical storage device, such as a magnetic diskette device, a CD-ROM, or other storage device. In each case, an appropriate device controller and interface (not shown) would be included along with the memory 12. The imaging logic 8, memory 12, and I/O port 10 are preferably under the control of a microprocessor 14, which is preferably a general purpose digital microprocessor operating under instructions stored in the memory 12 or a ROM 16. Stored instructions could also be provided via the I/O port 10 directly to the microprocessor 14 or stored in the memory 12 or the ROM 16.

[0019] In the preferred embodiment, the sensor array 6 is formed of an array of CMOS sensor cells, thus allowing for the imaging logic 8 to be formed using CMOS processes on a single integrated circuit along with the sensor array 6. Figure 2 illustrates a single integrated circuit (IC) 20, upon which is realized both the sensor array 6 and the imaging logic 8 according to the preferred embodiment of the invention. Other features and circuits may be included within the IC 20 including internal control registers, microprocessor interface logic, memory interface logic and the like. These features have not been illustrated as they are not necessary for an understanding of the present invention.

[0020] Further details of the imaging logic 8 will now be described with reference to Figure 2. The main path for imaging signals is indicated by heavy arrows. The analog signal from the sensor array 6 is passed to the buffer 22 where the signal is buffered to strengthen the signal and fixed pattern noise is removed. From the buffer 22 the buffered analog signal is sent to a first input of a programmable gain differential amplifier 24. The second input of the amplifier 24 receives a reference voltage V_{REF} which is fed from a reference control block 26 under the control of a digital signal controller 28. The amplifier 24 also receives a gain control signal from the gain control block 30, which operates under the control of a digital signal controller 28.

[0021] The amplifier 24 maps the two inputs to fully differential outputs 25 and 27. In other words, the outputs 25 and 27 correspond to the difference between the value of the two input signals (i.e. the analog image signal and the reference voltage V_{REF}) multiplied by the gain value and centered about a common mode voltage level. These fully differential outputs 25 and 27 are then fed to the inputs of a differential analog to digital converter 32 where the differential value (i.e. the difference between the signals 25 and 27) is converted to a digital

value. The resulting digital image signal is then passed to a defective-pixel filter 34 where image errors are detected and corrected, as described in detail below.

[0022] The corrected digital image signal is then passed to a digital micro-interface 36 which provides an interface between the IC 20 and other components of the digital imager 2, such as the memory 12, microprocessor 14 or I/O port 10.

[0023] Also shown in Figure 2 is a digital timing generator 42 which provides timing signals for operation of a sequential correlated doubling sampling block 44 in order to suppress CMOS sensor fixed pattern noise as taught in co-pending patent application 09/223,165, entitled Sequential Correlated Double Sampling Techniques for CMOS Area Array Sensors, which application is incorporated herein by reference. A row / column information register 46 provides information to the digital signal controller 28 and a digital average calculator 38 regarding where the signal currently being processed originated on the sensor array (i.e. provides row and column information for each pixel). The imaging logic 8 also includes a digital signal feedback loop comprising the digital average calculator 38, digital signal controller 28, reference control block 26, gain control block 30 and exposure time control 40. This feedback loop is employed to provide for optical black calibration and for resolution enhancement by adjusting the reference voltage and gain for the amplifier 24.

[0024] Further details regarding the design and operation of the defective-pixel filter 34 will now be discussed. Referring first to Figures 3a through 3j, each drawing illustrates a group of three neighboring pixels in the image signal. The pixels are illustrated as bars, which bars correspond to the luminance value for the given pixel. For instance in Figure 3a, the pixel B 52 has a luminance value greater than that of the pixel A 50 and the pixel C 54 has a luminance value greater than that of the pixel B. The pixels A, B and C correspond to three adjacent pixels in the CMOS array 6. Under normal circumstances, one would not expect abrupt discontinuities in the change in luminance values. For instance, as the image changes from dark to light, the pattern shown in Figure 3a, with the pixels having increasing values, would be expected. Likewise, in Figure 3b, the pixel B 52 is darker than the pixel A 50 and the pixel C 54 is darker than the pixel B 52 - indicating a normal transition from light to dark. Note that in both Figures 3a and 3b, the luminance for the middle pixel B 52 falls in the range of values defined by the luminance for its neighboring pixels A 50 and C 54. By contrast, in Figure 3c, the middle pixel B 52 has a luminance that is greater than the luminance of both of its neighbors 50 and 54, indicating a discontinuity in the luminance trend for the image. Note, however, that the pixel B 52 of Figure 3c deviates from its nearest neighbor pixel C 54 by an amount t . The value t indicates a threshold deviation between neighboring pixels that can be tolerated before the middle pixel will be considered as defective. Like-

wise, in Figures 3d through 3f even though the luminance of the middle pixel B 52 does not fall between the luminance of its neighboring pixels A 50 and C 54, the deviation from the nearest pixel value is equal to or less than t . By contrast, in Figures 3g through 3j the luminance value for the middle pixel B 52 does not fall within the range of values between the neighboring pixels A 50 and C 54, and also deviates from the value of the nearest pixel by more than the threshold amount t . Under the circumstances illustrated in Figures 3g through 3j, the pixel B 52 will be considered to be defective.

[0025] In practice a row of pixels forming the image will be scanned with a moving three-pixel window as shown in Figures 4a through 4b. A pixel data stream preferably consists of 10-bit luminance values for each pixel of the CMOS array 6, which stream is fed to the defective-pixel filter 34. The defective-pixel filter 34 applies a moving window 60 across the pixel data stream as it passes through the filter. In Figure 4a, the first three pixels 50, 52, 54 of the stream are analyzed, with the pixel 52 being the middle pixel B under consideration (as illustrated, pixel data is moving from right to left). In Figure 4b, the moving window 60 has shifted one pixel or, more accurately, the pixels moving through defective-pixel filter 34 have shifted by one pixel, and the pixels 52, 54, and 56 are then analyzed, with the pixel 54 being the middle pixel B under consideration. Finally, in Figure 4c, the moving window has again shifted by one pixel and the pixels 54, 56, and 58 are analyzed, with the pixel 56 being the middle pixel B under consideration.

[0026] In the event that the pixel B under consideration is determined to fall outside the range of luminance values of its neighboring pixels A and C, and to deviate from its nearest neighboring pixel by more than the threshold t , then that pixel will be flagged as defective. In the preferred embodiments, the luminance value for the defective pixel will be replaced with an interpolated luminance value based upon the values of the neighboring pixels A and C.

[0027] Further details regarding the defective-pixel filter 34 is provided with reference to Figure 5. The incoming pixel data is fed to a first in first out (FIFO) register comprising register cells 70, 72, 74, 76, and 78. While the preferred embodiment provides for the advantageous feature that defective pixels are identified and corrected for in real-time without the need for large memory storage, other embodiments might provide for a DRAM, SRAM or other type of memory in which the incoming pixel data is fed and stored. Note that five pixels are loaded into the FIFO registers even though only three pixels are analyzed at one time. This is because the defective-pixel filter 34 can be configured for both monochrome images and for color images. As is known in the art, color image sensors interlace the pixel sensors on each row in a Bayer pattern, as is illustrated in Figure 6, which illustrates a portion of a color image sensor. In the first row 100 of the array, red sensors 102,

104, 106 are interlaced with green sensors 103, 105, 107. In the second row 101, green sensors 108, 110, 112 are interlaced with blue sensors 109, 111, and 113. Clearly it is desirable to compare adjacent pixels of the same type (i.e. comparing red pixels to red pixels). For this reason, every other pixel should be selected for analysis, for instance pixels 102, 104, and 106 would be analyzed to determine if the pixel 104 was defective. Next, the pixel 105 would be compared to like pixels 103 and 107. Otherwise, if the (green) value for the pixel 103 was compared to the (red) values of pixels 102 and 104, it would be very likely to have abrupt discontinuities, even though the pixel 103 was functioning normally. For instance, for a portion of the image in which the image was primarily red, pixels 102 and 104 would be expected to have high luminance values and the pixel 103 would be expected to have very low luminance values.

[0028] Therefore, in the monochrome mode, the pixel A is selected from the register 72, the pixel B is selected from the register 74 and the pixel C is selected from the register 76. In the color mode, the pixel A is selected from register 70, the pixel B is selected from the register 74, and the pixel C is selected from the register 78, in order to ensure that like pixels are being compared.

[0029] A multiplexer 80 selects the pixel A from either the register 72 or from the register 70 depending on whether the device is in the monochrome or color mode, and feeds the pixel value to a comparator 82. In the comparator 82, the value of the pixel A is compared to the value of the pixel B from the register 74. If the comparison indicates that the pixel A has a greater value than the pixel B, a valid logic signal (logical high) is asserted on a signal line 86, which is connected to one input of a two-input AND gate 88. The other input to the AND gate 88 is fed from the comparator 96 wherein the value for the pixel B is compared to the value for the pixel C. The pixel C is selected by a multiplexer 98 from either the register 78 or the register 76, depending upon whether the device is in the monochrome or color mode. If the pixel B is greater in value than the pixel C, then the comparator 96 will assert a valid signal on a signal line 120, which is fed to the second input of the AND gate 88. If both inputs to the AND gate 88 are high (indicating that A is greater than B and B is greater than C), the AND gate 88 will assert a valid signal (logical high) to a four-input OR gate 122. This condition corresponds to the situation illustrated graphically in Figure 3b, which is an acceptable situation indicating that the pixel B is valid. The logical OR gate 122 will assert a valid signal (logical high) to a multiplexer 124, which will in turn allow the value for the pixel B, from the register 74, to be output from the defective-pixel filter 34 for further processing. Note that for convenience, a logical high signal will be treated as indicating a valid signal, although in other embodiments, a logical low signal could be used for a valid logic signal.

[0030] At the same time, the difference in the values of the pixel A and the pixel B is calculated in a block 90 and the difference is compared to the threshold t in a comparator 92. Note that the value for the threshold t can be selected by a user and stored in a register 94. Alternatively, or if no value for t is selected by the user, a default value for t can be stored in the register 94. In some embodiments, the threshold value can be automatically generated based upon an iterative process in which a feedback signal indicative of image quality is compared to a varying value for t until a threshold value is reached that effectively cancels out defective pixels without canceling out desired luminance variations that occur naturally in the image.

[0031] If the difference between the pixels A and B is less than or equal to the threshold, this also indicates that the pixel B is valid, corresponding to the condition in Figures 3d or 3f. Note that it does not matter whether the pixel B is greater than or less than the pixel A, as long as the difference is less than or equal to the threshold. If so, then the comparator 92 will output a logical high to the OR gate 122, which will also cause the multiplexer 124 to allow the pixel B to be passed.

[0032] Likewise, if the difference between the pixels B and C is less than or equal to the threshold value, corresponding to Figure 3c or 3e, then the pixel B is valid (regardless of the difference in value between the pixels A and B). This condition is determined by a block 126 and a comparator 128 and if the difference between pixels the B and C is less than t , a logical high is asserted to an OR gate 122 and the value for the pixel B is passed to the output from the register 74 via a multiplexer 124.

[0033] The fourth input of the OR gate 122 is fed from an AND gate 130. The first input to the AND gate 130 is the inverted output of the comparator 82 (via an inverter 132) and the second input is the inverted output of the comparator 96 (via an inverter 134). The AND gate 130 will output a valid signal (logical high) to the OR gate 122 when the pixel C is greater in value than the pixel B and the pixel B is greater in value than the pixel A. This corresponds to Figure 3a.

[0034] If none of the above conditions is met, the inputs to the OR gate 122 will be logical lows, and hence the control input to the multiplexer 124 will be a logical low. This indicates that the pixel B is defective (corresponding to one of the conditions of Figures 3g through 3j). Under those circumstances, the multiplexer 124 will pass a corrected pixel B value to the output. This corrected pixel value is calculated in a block 136. In the preferred embodiments, the corrected pixel B value is calculated from the average value of its neighboring pixels A and C. In other words, $B_{corrected} = (A + C) / 2$. The advantage of using a simple interpolation between the pixels A and C is that those values are already stored in the FIFO register. More complex interpolations could be employed to generate the value for $B_{corrected}$, such as using the values of the nearest two or three

neighbors on either side of B, but such interpolations would require additional storage elements in which the neighboring pixel values are stored and would also require additional combinational logic (with its associated costs and real estate requirements).

[0035] In the preferred embodiments, the circuit of Figure 5 is realized in combinational logic on a semiconductor chip using CMOS fabrication processes. Advantageously, the preferred embodiment filter is fabricated on the same chip as the sensor array, as provided for with a CMOS sensor array. While other types of arrays such as CCD array may also be used, they may not be as desirable for reasons of processing differences. In other embodiments, the function could be achieved by a microprocessor running a sequence of program instructions. Alternatively, the circuitry could be realized in programmable gate array logic or other programmable logic.

[0036] As will be apparent from the above description, the preferred embodiments provide several advantageous features including the ability to eliminate temperature and time dependent pixel defects and the ability to filter both white pixels and dark pixels with adjustable thresholds. The adjustable threshold feature allows compensation for image spatial frequency and for degree of array pixel defects. Additionally, the preferred embodiments operate at high speed in real time and do not require a frame or line memory to store an entire frame or line of data. Both the logic and the sensor array can be formed on a single chip and are compatible with CMOS operations. The method can be employed as a part of a wafer probe operation in order to determine wafer yield and is operable in either color or monochrome image modes. The described embodiments maintain high frequency edge components, such as a rapid transition from a dark to very bright object, or from a bright to dark object.

[0037] While this invention has been described with reference to illustrative embodiments, this description is not intended to be construed in a limiting sense. Various modifications and combinations of the illustrative embodiments, as well as other embodiments of the invention, will be apparent to persons skilled in the art upon reference to the description. It is therefore intended that the appended claims encompass any such modifications or embodiments.

Claims

1. A filter for filtering an image which includes a plurality of picture elements each represented by a luminance or a chrominance value, including:

means for selecting a picture element and its two adjacent picture elements,
means for determining whether the selected picture element lies between the two adjacent picture elements in value,

means for determining whether the selected picture element differs in value from both of the two adjacent picture elements by more than a set amount and

means for replacing the selected picture element, in value, by a value dependent on the two adjacent picture elements, when, in value, the selected picture element does not lie between the two adjacent picture elements and differs from both of the two adjacent picture elements by more than the set amount and means for repeating the procedure for further picture elements serving as the selected picture element.

2. A filter as claimed in claim 1, including means for replacing the selected picture element, in value, by an average of the values of the two adjacent picture elements.

3. A filter as claimed in claim 1, including means for replacing the selected picture element, in value, by an interpolation dependent on the values of the two adjacent picture elements.

4. A filter as claimed in any one of claims 1 to 3 comprising: a first comparator circuit for receiving as input a first picture element value and a second picture element value and outputting a valid logic signal to a first input of an AND circuit and to a first inverter when the first picture element value is greater than the second picture element value,

a first difference calculator for receiving as input said first picture element value and said second picture element value and outputting to a first input of a second comparator circuit a first difference value corresponding to the difference between said first and second picture element values;

said second comparator circuit also for receiving as input a threshold value and outputting a valid logic signal to a first input of an OR circuit when the first difference value is less than or equal to the set amount;

a third comparator circuit for receiving as input said second picture element value and a third picture element value and outputting a valid logic signal to a second input of said first AND circuit and to a second inverter when the second picture element value is greater than the third picture element value and

a second difference calculator for receiving as input said second picture element value and said third picture element value and outputting a second difference value corresponding to the difference between said second and third picture element values to a first input of a fourth

comparator circuit,

said fourth comparator circuit also for receiving as input the set amount threshold value and outputting a valid logic signal to a third input of said OR circuit when the second difference value is less than or equal to the set amount and

a second AND circuit coupled to said first and second inverters and having an output coupled to a fourth input of said OR circuit.

5. A filter as claimed in claim 4 further comprising:

a corrected picture element calculation block for receiving as input said first and third picture element values and outputting a corrected picture element value,

a multiplexer having a first input coupled to the output of said corrected picture element calculation block and receiving as a second input said picture element value and having a control input coupled to an output of said OR circuit.

6. A filter as claimed in any one of claims 1 to 5, further comprising registers for storing picture element values.

7. A filter as claimed in any one of claims 4 to 6, capable of operating in both monochrome and color mode and further comprising:

at least one multiplexer for receiving as input the picture element values stored in at least two registers and outputting one of said picture element values in response to an indication of monochrome or color mode operation.

8. A filter as claimed in any one of claims 4 to 7, wherein said first, second, and third picture element values are ten bit digital values.

9. A filter as claimed in any one of claims 1 to 8, further comprising a threshold value register for storing the said set amount.

10. A filter as claimed in claim 9, including means permitting a user to enter the set amount in the threshold value register.

11. A filter as claimed in claim 9, including means for providing the set amount from a feedback signal indicative of image quality.

12. A filter as claimed in any one of claims 4 to 8, wherein said comparator circuits, difference calculators, and registers are fabricated with CMOS processes.

13. A filter as claimed in any one of claims 1 to 12, including a general purpose microprocessor.
14. A digital imaging device including a filter as claimed in any one of claims 1 to 13 comprising: 5
 a substrate,
 a sensor array formed on the substrate, the array generating an electrical signal corresponding to the amount of light impinging upon the array and 10
 imaging logic formed on the substrate, coupled to the sensor array and receiving the electrical signal, the imaging logic including an analog to digital converter receiving the electrical signal and outputting digital picture element values. 15
15. A digital imaging device as claimed in claim 14, further comprising a first in first out register wherein said picture element values are stored. 20
16. A digital imaging device as claimed in claim 14 or claim 15, wherein the filter operates in real time.
17. A digital imaging device as claimed in any one of claim 14 to 16, wherein the sensor array is comprised of CMOS cells. 25
18. A digital imager including a filter as claimed in any one of claims 1 to 13 comprising: 30
 a lens mechanism,
 a sensor array positioned within a focal plane of said lens mechanism,
 an analog buffer and amplifier coupled to an output of said sensor array and 35
 imaging logic coupled to said amplifier, the filter being included in the said imaging logic.
19. A digital imager as claimed in claim 18, wherein said sensor array and said imaging logic are fabricated on a single integrated circuit. 40
20. A digital imager as claimed in claim 18 or 19, wherein the sensor array is comprised of CMOS cells. 45
21. A digital imager as claimed in claim 18 or 19, wherein the sensor array is comprised of CCD cells. 50
22. A digital imager as claimed in any one of claims 18 to 21, wherein the imaging logic includes combinational logic. 55
23. A digital imager as claimed in any one of claims 18 to 22, wherein the imaging logic includes a micro-processor.
24. A method of filtering an image including a plurality of picture elements each represented by a luminance or a chrominance value, including the steps of:
 selecting a picture element and its two adjacent picture elements,
 determining whether the selected picture element lies, in value, between the two adjacent picture elements,
 determining whether the selected picture element differs, in value, from both of the two adjacent picture elements by more than a set amount and
 when the selected picture element does not lie, in value, between the two adjacent picture elements and differs from both of the two adjacent picture elements by more than the set amount, replacing the selected picture element, in value, by a value dependent on the two adjacent picture elements,
 the procedure being repeated for further picture elements serving as the selected picture element.
25. A method as claimed in claim 24 comprising:
 determining a first difference value between the luminance value of the selected picture element and the luminance value of a first neighboring picture element,
 comparing the first difference value to the set value,
 determining a second difference value between the luminance of the selected picture element and the luminance value of a second neighboring picture element,
 comparing the second difference value to the set value,
 detecting whether the luminance value for the selected picture element falls within an acceptable range defined by the luminance value for the first neighboring picture element and the luminance value for the second neighboring picture element and
 identifying the selected picture element as defective if the luminance value for the selected picture element does not fall within the acceptable range and neither the first difference value nor the second difference value is less than or equal to the set value.
26. The method as claimed in claim 24 or claim 25, wherein an average of the luminance value of the first neighboring picture element and the luminance value of the second neighboring picture element replaces the selected picture element in value.

- 27. A method as claimed in claim 24 or claim 25, wherein an interpolated value taking account of two or more neighboring picture elements on either side of the selected picture element replaces the selected picture element in value. 5
- 28. A method as claimed in any one of claims 24 to 27, wherein the set value is entered in a register by a user. 10
- 29. A method as claimed in any one of claims 24 to 27, wherein the set value is determined from a feedback signal indicative of image quality.
- 30. A method as claimed in any one of claims 24 to 29, performed in real time. 15

20

25

30

35

40

45

50

55

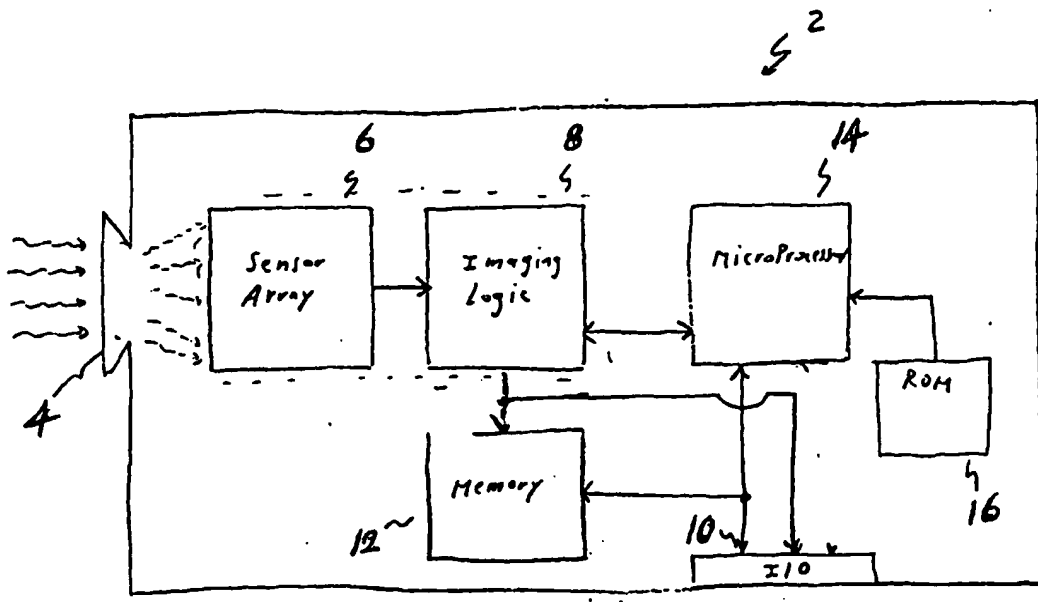

Figure 1

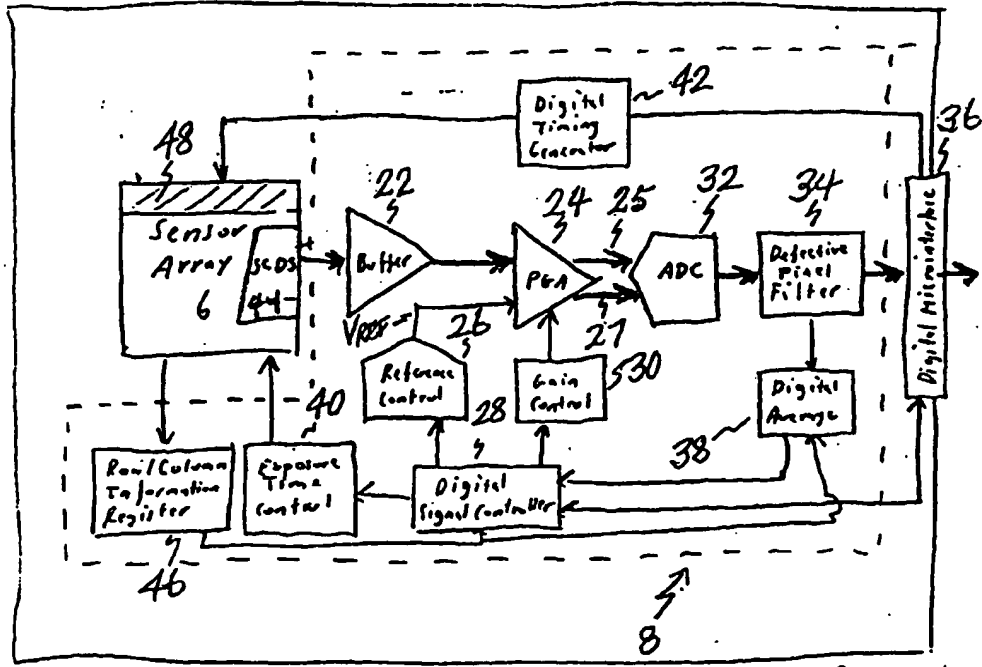
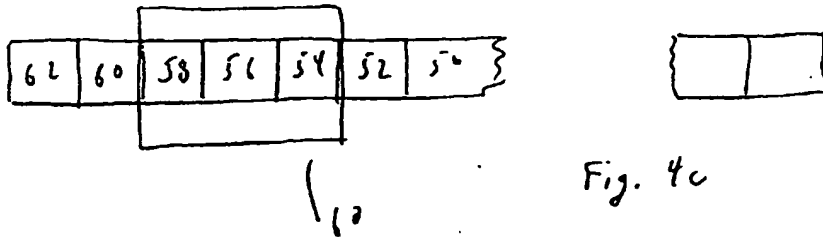
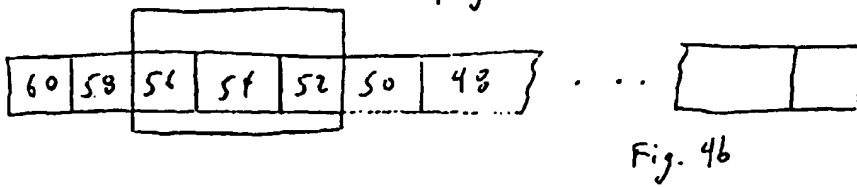
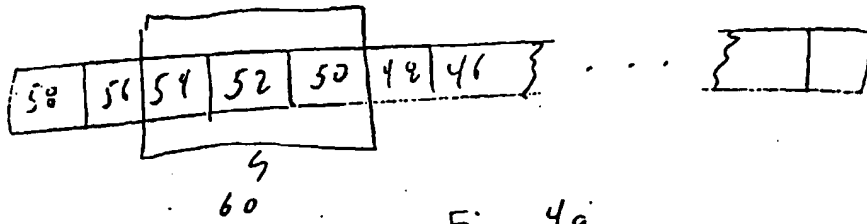
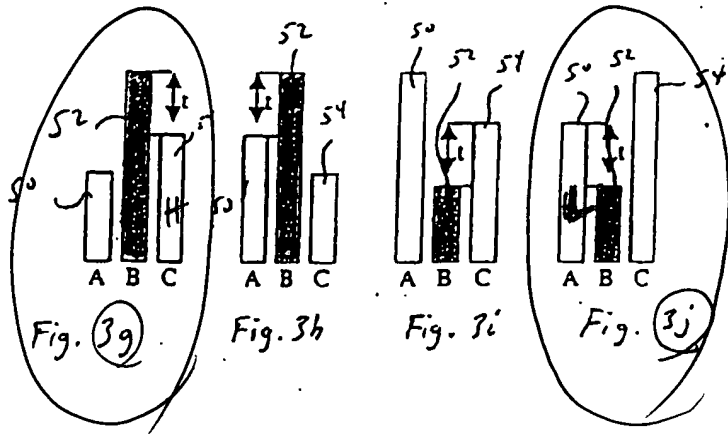
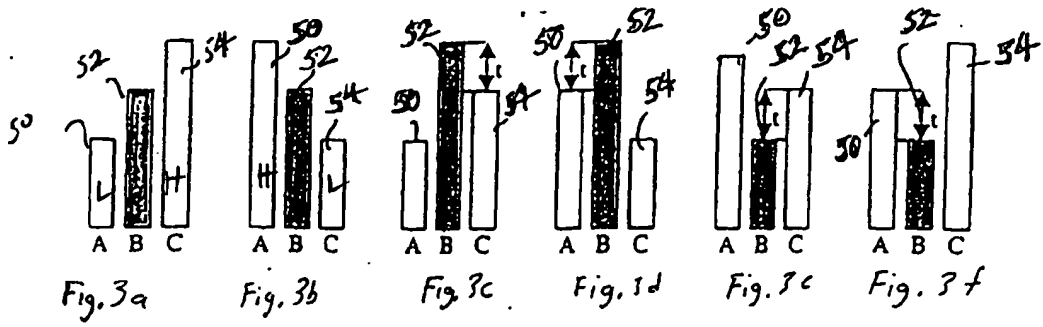

Figure 2



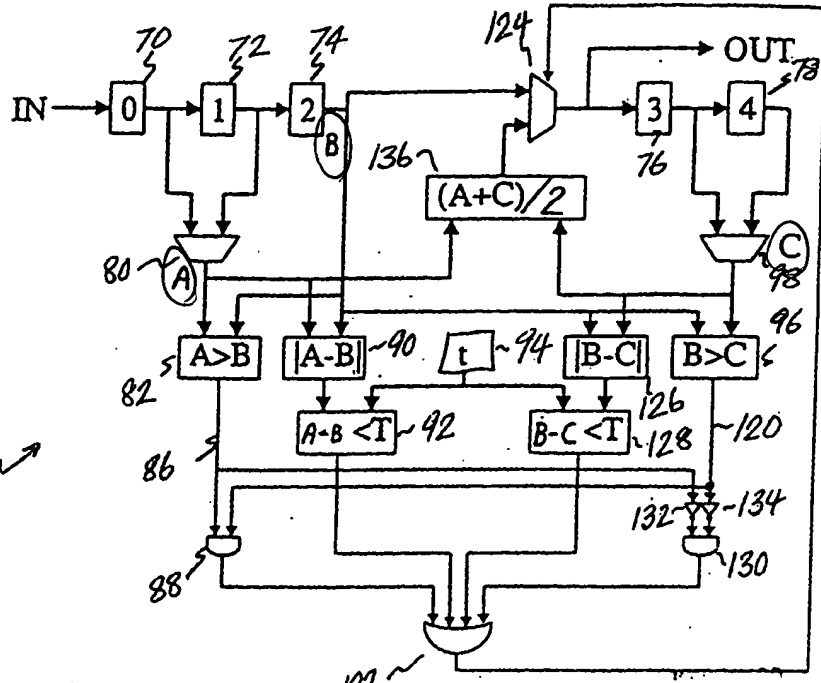

figure 5

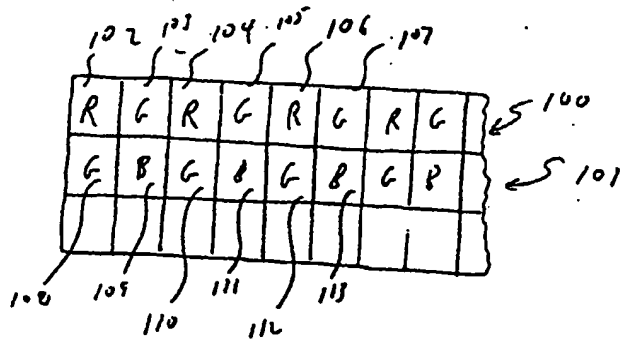

Fig. 6